

Scale: 2:1

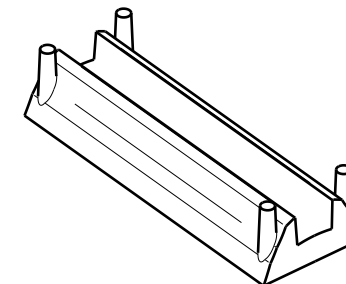

Scale: 1:1

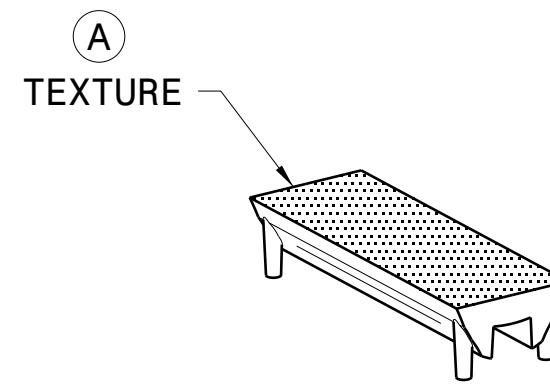
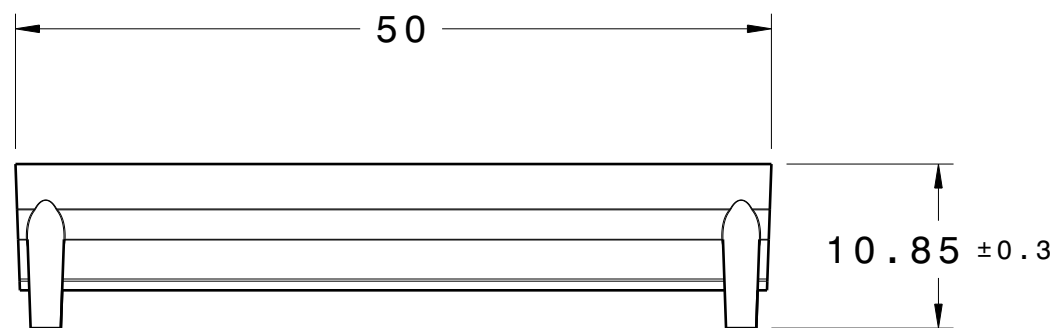
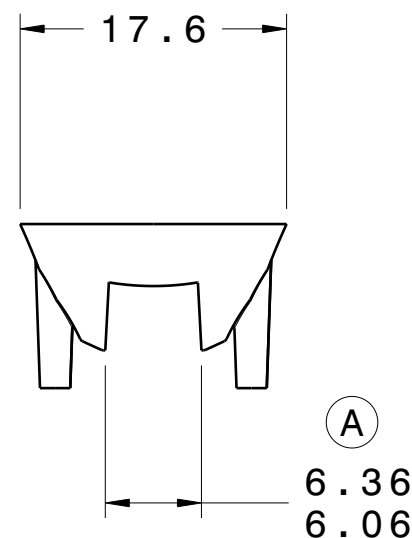

NOTES:

- MATERIAL : CLEAR ACRYLIC
- WEIGHT : 5.1 g
- DIMENSIONS IN MM

Département:

CHEF DE PROJETS:
GEORGE IATAN

DATE DIFFUSÉ:

NOM DU FICHIER:
DBM17A-30F-L100W-1 (C-001).CATPart

MÉTHODES:
KEITH ROSS

DATE DESSINÉ:
24 OCT 2008

No. DE DESSIN:
C-001-A

DESSINATEUR OPTIQUE:
ERIC MARCOUX

VÉRIFIÉ PAR:
/ /

ÉCHELLE:
1 : 1

FOLIO:
1 / 1

DESSINATEUR:
MARTIN HARNOIS

TITRE:

C-001
LENS

(A) 24 OCT 2008 MH

DIMENSION ADDED
NOTE ADDED FOR
TEXTURE

MODIFICATION

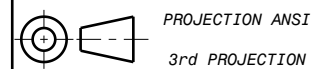

TOLÉRANCE GÉNÉRALES /
GENERAL TOLERANCES

ALL DIMENSIONS ARE
ACCORDING TO SPI/SPE
COMMERCIAL CLASS UNLESS
SPECIFIED

ANGLES ±0°15'
SAUF INDICATION CONTRAIRE /
UNLESS OTHERWISE INDICATED



DBM REFLEX ENTREPRISES INC.
1620 DAGENAIS OUEST LAVAL, QUÉBEC, CANADA, H7L 5C7